

# **XL-1**

---

XL4600

**NOTE:** Owner's manual not to be removed by anyone but the occupant.

## **Owner's Manual**

---



FIRE BURGLARY INSTRUMENTS, INC.  
A Subsidiary of Pittway Corp.

N9111 6/92  
©1992, FBX



# 1. KEYPAD LAYOUT

The keypad is the device used to control your security system. Various keypads are available for use with the system. They utilize either indicator lights (LEDs) or a liquid crystal display (LCD) section containing a two line readout.

The available keypads include:

- XL4600RM Metal Plate, Flush Mounted, LED Keypad
- XL4600SM Surface Mounted, LED Keypad
- 6615 Plastic Case, Surface Mounted, LED Keypad
- 6805 Plastic Case, Surface Mounted, LCD Keypad

Your system will have one or more keypads, which may be identified by means of the following illustrations:

## LED Type Keypads

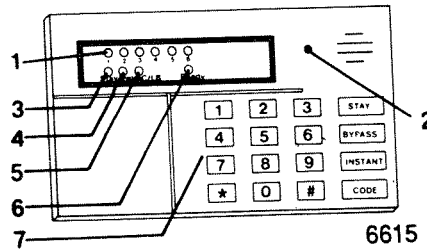
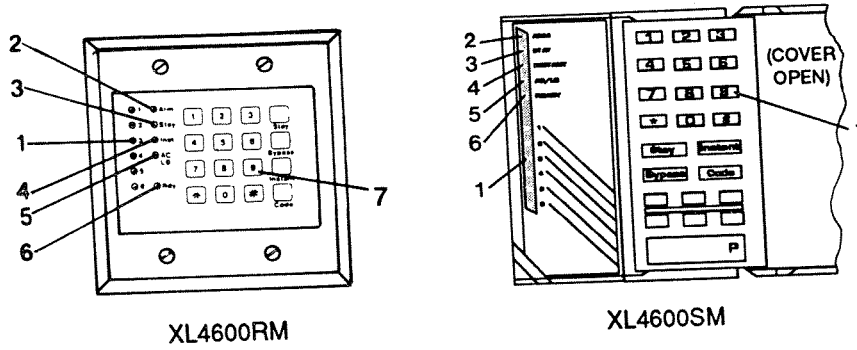

## LCD Type Keypads

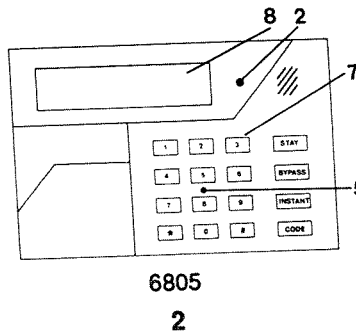

1) **ZONE STATUS INDICATORS** - displays the current zone status as follows;

ALARM	Fast blinking.
BYPASS	Slow blinking low intensity.
TROUBLE	Slow pulse
NOT READY	Solid ON

2) **ARM/DISARM INDICATOR** - Shows whether the system is currently armed (ON) or disarmed (OFF). In addition, this indicator will blink during a fire alarm (see below) or upon failure to communicate with the central station (see section 14 for additional central station information).

3) **STAY** - shows the system has been armed with the interior zones bypassed.

4) **INSTANT** - shows whether the system has been ARMED with all delay zones instant.

5) **AC/LOW BATTERY** - shows whether the system is running on AC (ON) or backup battery (OFF).

6) **READY** indicates whether the system is ready for arming.

7) **NUMERICAL KEYPAD** operates in a similar manner to a calculator or telephone with the digits 0 - 9 and \*# clearly marked.

8) **DISPLAY AREA** - This section of the LCD keypad displays the current system status in this two line by sixteen character display.

Throughout this user's manual the following conventions are used to display the keystrokes required to perform the functions.

<b>BYPASS</b>	Key labeled BYPASS on keypad
<b>INSTANT</b>	Key labeled INSTANT on keypad
<b>STAY</b>	Key labeled STAY on keypad
<b>CODE</b>	Key labeled CODE on keypad
<b>[USER]</b>	Four digit user code.

### **FIRE ALARM AUDIBLE AND VISUAL INDICATIONS**

When fire protection is used, the equipment will give priority to a fire alarm indication.

**On LED type keypads** the programmed fire zone LED and the Arm LED blink fast when a fire condition exists.

**On an LCD keypad** the word "ALARM" will flash in the display area.

**The sounder in each keypad** will pulse on and off in time with the bell or siren output.

Please see Section 13 for more fire information.

**A FLASHING READY LED OR A DISPLAY OF THE WORDS "PROGRAMMING MODE STANDBY"** indicates that the unit is in the installer programming mode. The fire and burglary initiating circuits are disabled while in this mode. Contact your installer if this mode persists.

## 2. ARMING THE SYSTEM

ARMING the system will activate all portions of your Security System. Arming can only be performed if all zones are READY. For example, if a protected door is open the system cannot be armed.

### SYSTEM READY

The system is ready to be armed if the READY indicator light is ON. On LCD keypads the following display will appear:

**SYSTEM READY**

If the system is ready, ARMING can be performed as follows;

### ARMING PROCEDURE:

1. Enter your four digit user code into the keypad:

[USER]

The ARMED indicator light will now be lit and if you are leaving the home you may exit through a door designated by your installer as an exit/entry zone for a fixed time period known as the exit delay.

The entry/exit times for your system are as follows;

ENTRY: \_\_\_\_\_seconds- EXIT: \_\_\_\_\_seconds

LCD keypads will display the following message;

**ON AWAY.....**

**NOTE:** The system can be armed without the backup battery being connected.

### SYSTEM NOT READY

If the system is not ready to be armed the READY indicator will be OFF. On LED based keypads the zone indicator lights will display the zones which are currently not ready. The condition of each zone indicator reflects the status of each zone as follows;

ALARM

Fast blinking

BYPASS

Slow blinking low intensity

TROUBLE

Slow pulse

NOT READY

Solid ON

The LCD keypad will display zones which are not ready with a SYSTEM NOT READY message on the first line and the zone(s) that are not ready on the second line as shown below;

**SYSTEM NOT READY  
ZONE 3**

The second line of the display will scroll through multiple zones not ready.

In order to make the system ready, determine which zones are not ready by observing the zone indicator lights, or the display section of the LCD keypad. From the zone number you can find out which area of protection is not ready.

For example, assume the zone 3 is not ready. Typically this might mean that a protected door or window is open.

➤ Once the problems with each zone have been resolved, the READY light will appear and the system can be armed.

To ARM the system when the alarm when the system is NOT READY, one of the following actions is necessary;

-Make the zone(s) ready. Determine which zones are not ready and perform what is necessary to ready the zone(s) (example, close the door or window, etc.), or

-Bypass the zone(s) not ready. Bypassing should only be performed if the zone cannot be made ready or intentionally will remain not ready. **Remember, zones that are bypassed are not protected when the system is armed.**

### 3. DISARMING

Disarming the security system will deactivate the burglary portions of the system.

This procedure can also be used to reset your system if you accidentally set off the system (example, opened a window while the system was armed, or excessive amount of smoke activated fire protection system).

#### DISARM PROCEDURE:

[USER]

Enter your user code.

#### IF NO ALARMS HAVE TAKEN PLACE

Upon disarming, the ARMING indicator will go off.

The system display will reflect the current status. LCD keypads should display the SYSTEM READY display.

#### IF ALARMS HAVE TAKEN PLACE

If alarms or other conditions such as system troubles have taken place since the initial system arming, they will appear on the display. The conditions that have occurred appear in the zone display section of the keypad. LED keypads will reflect the current system status through the zone indicator lights as follows;

ALARM

Fast blinking

BYPASS

Slow blinking low intensity

TROUBLE

Slow pulse

NOT READY

Solid ON

Burglary alarms will be indicated with a STEADY sound through the keypad while FIRE alarms will generate a pulsing sound. LCD keypads will show the alarm conditions with a display as follows:

ALARM  
ZONE 3

The second line of the display will scroll through multiple zones which are in alarm. After entry of your user code the display will show the following (scrolling, if any, will continue):

ALARM MEM  
ZONE 3

If an intrusion has taken place while you were away, do not enter until the location has been secured!!!

>> To clear the display of the alarm or trouble conditions and silence the audible signal enter [USER] again.

## **4. STAY**

---

The STAY mode is another way to ARM your system while you remain in the location. The STAY mode will deactivate any interior protection zones which means that you will be free to walk throughout your location without activating the alarm system.

In order to enter the STAY mode, the system must be READY. (see previous description).

### **STAY PROCEDURE:**

#### **STAY [USER]**

Depress the STAY key followed by your user code.

After a successful STAY arming the ARMED indicator will be lit. In addition, on LED keypads the STAY indicator will be lit. In LCD keypads the following display will appear;

**ON: STAY**

In the STAY mode only the external or perimeter burglary protection is active. You are free to walk around the residence without activating any of the interior protection zones.

>> Remember, you must DISARM the system when you want to leave the premises.

Note: The STAY option will automatically be reset after the system is disarmed

## **5. INSTANT**

---

The INSTANT mode arms the system and eliminates the entry time delay interval. With this mode used, if anyone enters through an entry/exit zone the alarm system will instantly activate.

The system must be READY in order to select the INSTANT option.

### **INSTANT PROCEDURE:**

#### **INSTANT [USER]**

Depress the INSTANT key followed by your user code.

Upon successful INSTANT ARMING of the system the ARMED indicator will be lit. In addition, on LED keypads the Instant indicator will be ON. LCD keypads will contain the following message;

**ON: INSTANT**

Note: The INSTANT option will automatically be reset after the system is disarmed.

## **6. INSTANT - STAY**

---

The INSTANT STAY mode will arm the system with the characteristics of both the INSTANT and STAY modes. The system will be armed with the interior portions bypassed and the entry delay will be suspended.

The system must be READY in order to enter this mode.

**PROCEDURE:**

**INSTANT STAY [USER]**

or

**STAY INSTANT [USER]**

Depress the INSTANT and STAY keys in any order followed by your user code.

After a successful INSTANT STAY arming the ARMED indicator will be lit. In addition, on LED keypads both the INSTANT and STAY lights will be on.

LCD keypads will contain the following message;

**ON: STAY INSTANT**

## **7. BYPASS**

Bypasses are performed to eliminate burglary zones that are not ready or faulty when arming the security system. **Caution: Bypassing a zone leaves that area unprotected when the system is armed.**

**BYPASS PROCEDURE:**

**BYPASS [USER] ZN**

Depress the BYPASS key followed by your user code and zone number (1-6) to be bypassed.

Example:

**BYPASS [USER] 2** Will bypass zone 2

If the zone has already been bypassed, the sequence will unbypass the zone except if the system is armed and the unbypassed zone is still not ready. Unbypass means that the zone returns as an active burglary zone.

After the bypass (or unbypass) command has been accepted the unit will emit a continuous beep and zone or zones that have been bypassed will appear in a slow blinking mode in the zone status area on LED keypads. LCD keypads will display the zone bypasses on the second line of the display as shown below. The top line can contain either the SYSTEM READY or NOT READY message.

**SYSTEM READY  
ZONE 3**

The second line of the display will scroll through multiple zones which have been bypassed.

## **8. UNBYPASS**

The UNBYPASS function removes an existing bypass from a currently bypassed zone. After UNBYPASSING a zone, the bypass indication will be removed for that zone on either the LCD or LED keypad.

The procedure is similar to a bypass.

**UNBYPASS PROCEDURE:**

**BYPASS [USER] ZN**

See bypass description.



## 9. USER DEFINITION

---

Users can be entered or modified directly through the keypad. The security system can have up to six different users. User #1 is known as the master user and is the only user allowed to modify other users.

### USER DEFINITION PROCEDURE:

CODE [USER] [US #] [USER ID]

where;

[USER] Is the master user code (four digits).

[US #] User number (1-6)\*

[USER ID] New user ID (0000 - 9999).

Note: (\*) If ambush code capability has been enabled by your installing company then user #6 will be used as the system ambush code.

Example,

To create user number 3, with a user access code of 4567 enter;

CODE [USER] 3 4567

>> Any error detected during the USER definition process will cause the keypad to beep rapidly four times. If an error is detected retry the entire command.

## 10. USER DELETION

---

Removal of users from the panel can be performed as follows;

### USER DELETION PROCEDURE:

CODE [USER] [User #]\*

Where:

[USER] Master user code

[User #] Represents the user number being deleted.(2-6). Note:

User number 1 cannot be deleted.

\* is the \* key from the keypad.

## 11. KEYPAD PANIC

---

A panic signal can be sent directly through any of the keypads by pressing the # and \* keys at the same time. This panic signal can be set up to be silent or audible by your installing company. This panic signal is active 24 hours a day whether the system is armed or disarmed. On the XL4600SM keypad, a panic signal can **also** be transmitted by pressing the two keys marked [P] at the same time.

Consult your installing company to determine how the keypad panic operates on your system.

## 12. DURESS

---

The system has the capability to send an emergency signal to the Central Station if you are forced to enter the premises. This ambush capability can be programmed by your installer. If active, then user code #6 will be your ambush code.





# 13. INSTALLATION LAYOUT

Early warning fire detection is best achieved by the installation of fire detection equipment located as follows;

## Typical Smoke Detector Layout (Proposed)

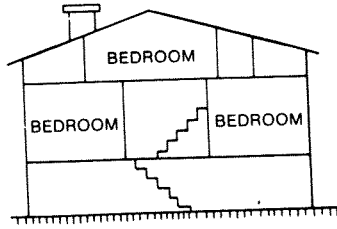

In homes with more than one sleeping area a smoke detector should be provided to protect each area.

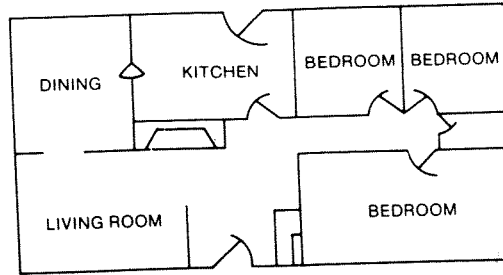

Smoke detector shall be located between the sleeping area and the rest of the house.

**NOTES:**

1. Designates smoke detectors.
2. Refer to N.F.P.A. #74 Appendix B-1.1 thru B-10.

Preparation of an evacuation plan is of prime importance in fire prevention. Establish a household emergency evacuation plan in the event of fire.

1. Evaluate possible escape routes from your home.
2. Select 2 escape routes from each room.
3. Rooms on the second floor should have a rope ladder. Be sure it will reach the ground.
4. Draw a rough sketch of your escape plan so everyone is familiar with it.
5. Practice your escape plan to assure that everyone knows what to do.
6. Establish a meeting place outside where your family is to report. Once you have evacuated the house do not return to a burning house.
7. Advise the local fire authority that you have installed a fire alarm system.
8. When the fire alarm signals, LEAVE IMMEDIATELY. Do not stop for belongings.
9. If a fire occurs, test the door. If hot, use your alternate route. If the door is cool, brace your shoulder against it and open it cautiously. Shut the door to help prevent the fire and smoke from spreading. Crawl through smoke, holding your breath.
10. Contact the Fire Department from a neighbor's telephone.
11. Everyone including neighbors should be familiar with the Fire and Burglary signals. In this installation the Fire Alarm signal is \_\_\_\_\_.  
The Burglary Alarm signal is \_\_\_\_\_.



## 14. SYSTEM TESTING

This control unit was manufactured under rigid quality standards and complies with all UL requirements for its intended use. Maintenance is best performed by your installing company with trained service personnel.

Installing Company: \_\_\_\_\_  
Telephone Number: \_\_\_\_\_

It is recommended that you test your system once a week using the following procedure:

Note: If your security system is monitored by a Central Station then contact them prior to performing this test.

1. Arm your security system.
2. Activate the system by opening a protected zone (example, window, or door).
3. Confirm that the alarm sounding device (bell or siren) activates. If your system is connected to a Central Station then the keypad will emit a ringback sound to confirm that the signal was received.
4. Disarm the system to silence the system and return to normal status.

### BATTERY TEST

In order to test the backup battery the following procedure should be performed;

1. Remove the AC transformer from the AC outlet by removing the retaining screw which secures the transformer to the wall. (Note: The screw is not present in models sold in Canada).
2. Observe that the AC light goes off on the keypad.
3. Activate your alarm system using steps 1-4 listed above.
4. Replace the AC transformer to the AC outlet and secure using the retaining screw (Note: The retaining screw is not present in models sold in Canada).

The National Fire Protection Association publishes a standard for household fire warning equipment. N.F.P.A. #74. Further information can be obtained by contacting; NFPA Public Affairs Dept., Batterymarch Park, Quincy, MA 02269.

If you have any further questions about the operation of your system, call your installer.

**WARNING!**  
**THE LIMITATIONS OF THIS ALARM SYSTEM**

While this System is an advanced design security system, it does not offer guaranteed protection against burglary, fire or other emergency. Any alarm system, whether commercial or residential, is subject to compromise or failure to warn for a variety of reasons. For example:

- Intruders may gain access through unprotected openings or have the technical sophistication to bypass an alarm sensor or disconnect an alarm warning device.
- Intrusion detectors (e.g., passive infrared detectors), smoke detectors, and many other sensing devices will not work without power. Battery-operated devices will not work without batteries, with dead batteries, or if the batteries are not put in properly. Devices powered solely by AC will not work if their AC power supply is cut off for any reason, however briefly.
- Signals sent by wireless transmitters may be blocked or reflected by metal before they reach the alarm receiver. Even if the signal path has been recently checked during a weekly test, blockage can occur if a metal object is moved into the path.
- A user may not be able to reach a panic or emergency button quickly enough.
- While smoke detectors have played a key role in reducing residential fire deaths in the United States, they may not activate or provide early warning for a variety of reasons in as many as 35% of all fires, according to data published by the Federal Emergency Management Agency. Some of the reasons smoke detectors used in conjunction with this System may not work are as follows. Smoke detectors may have been improperly installed and positioned. Smoke detectors may not sense fires that start where smoke cannot reach the detectors, such as in chimneys, in walls, or roofs, or on the other side of closed doors. Smoke detectors also may not sense a fire on another level of a residence or building. A second floor detector, for example, may not sense a first floor or basement fire. Finally, smoke detectors have sensing limitations. No smoke detector can sense every kind of fire every time. In general, detectors may not always warn about fires caused by carelessness and safety hazards like smoking in bed, violent explosions, escaping gas, improper storage of flammable materials, overloaded electrical circuits, children playing with matches, or arson. Depending on the nature of the fire and/or location of the smoke detectors, the detector, even if it operates as anticipated, may not provide sufficient warning to allow all occupants to escape in time to prevent injury or death.

(continued)



(continued)

- Passive Infrared Motion Detectors can only detect intrusion within the designed ranges as diagrammed in their installation manual. Passive Infrared Detectors do not provide volumetric area protection. They do create multiple beams of protection, and intrusion can only be detected in unobstructed areas covered by those beams. They cannot detect motion or intrusion that takes place behind walls, ceilings, floors, closed doors, glass partitions, glass doors, or windows. Mechanical tampering, masking, painting or spraying of any material on the mirrors, windows or any part of the optical system can reduce their detection ability. Passive Infrared Detectors sense changes in temperature; however, as the ambient temperature of the protected area approaches the temperature range of 90° to 150°F, the detection performance can decrease.
- Alarm warning devices such as sirens, bells or horns may not alert people or wake up sleepers if they are located on the other side of closed or partly open doors. If warning devices are located on a different level of the residence from the bedrooms, then they are less likely to waken or alert people inside the bedrooms. Even persons who are awake may not hear the warning if the alarm is muffled by noise from a stereo, radio, air conditioner or other appliance, or by passing traffic. Finally, alarm warning devices, however loud, may not warn hearing-impaired people.
- Telephone lines needed to transmit alarm signals from a premises to a central monitoring station may be out of service or temporarily out of service. Telephone lines are also subject to compromise by sophisticated intruders.
- Even if the system responds to the emergency as intended, however, occupants may have insufficient time to protect themselves from the emergency situation. In the case of a monitored alarm system, authorities may not respond appropriately.
- This equipment, like other electrical devices, is subject to component failure. Even though this equipment is designed to last as long as 20 years, the electronic components could fail at any time.

The most common cause of an alarm system not functioning when an intrusion or fire occurs is inadequate maintenance. This alarm system should be tested weekly to make sure all sensors are working properly. Installing an alarm system may make the owner eligible for a lower insurance rate, but an alarm system is not a substitute for insurance. Homeowners, property owners and renters should continue to act prudently in protecting themselves and continue to insure their lives and property.

We continue to develop new and improved protection devices. Users of alarm systems owe it to themselves and their loved ones to learn about these developments.



# OWNER'S INSURANCE PREMIUM CREDIT REQUEST

This form should be completed and forwarded to your homeowner's insurance carrier for possible premium credit

## A. GENERAL INFORMATION:

Insured's Name and Address: \_\_\_\_\_  
\_\_\_\_\_  
\_\_\_\_\_

Insurance Company: \_\_\_\_\_ Policy No.: \_\_\_\_\_

Fire Burglary Instruments Security System

Type of Alarm:  Burglary  Fire  Both

Installed by: \_\_\_\_\_ Serviced by: \_\_\_\_\_  
Name Name

\_\_\_\_\_ Address Address

## B. NOTIFICATIONS

Local Sounding Device: \_\_\_\_\_ Police Dept.: \_\_\_\_\_ Fire Dept.: \_\_\_\_\_

Central Station: \_\_\_\_\_

Name: \_\_\_\_\_

Address: \_\_\_\_\_  
\_\_\_\_\_  
\_\_\_\_\_

C. POWERED BY: A.C. With Rechargeable Power Supply

D. TESTING:  Quarterly  Monthly  Weekly  Other \_\_\_\_\_

E. SMOKE DETECTOR LOCATIONS

- Furnace Room  Kitchen  Bedrooms  Attic  
 Basement  Living Room  Dining Room  Hall

Other \_\_\_\_\_

F. BURGLARY DETECTION DEVICE LOCATIONS:

- Front Door  Basement Door  Rear Door  All Exterior Doors  
 1st Floor Windows  All Windows  Interior Locations  
 All Accessible Openings, Including Skylights, Air Conditioners and Vents

Other \_\_\_\_\_

G. ADDITIONAL PERTINENT INFORMATION:

\_\_\_\_\_  
\_\_\_\_\_  
\_\_\_\_\_  
\_\_\_\_\_

Signature: \_\_\_\_\_ Date: \_\_\_\_\_

## FEDERAL COMMUNICATIONS COMMISSION (FCC) STATEMENT

This equipment has been tested to FCC requirements and has been found acceptable for use. The FCC requires the following statement for your information:

This equipment generates and uses radio frequency energy and if not installed and used properly, that is, in strict accordance with the manufacturer's instructions, may cause interference to radio and television reception. It has been type tested and found to comply with the limits for a Class B computing device in accordance with the specifications in Part 15 of FCC Rules, which are designed to provide reasonable protection against such interference in a residential installation. However, there is no guarantee that interference will not occur in a particular installation. If this equipment does cause interference to radio or television reception, which can be determined by turning the equipment off and on, the user is encouraged to try to correct the interference by one or more of the following measures:

- If using an indoor antenna, have a quality outdoor antenna installed.
- Reorient the receiving antenna until interference is reduced or eliminated.
- Move the radio or television receiver away from the control/communicator.
- Move the antenna leads away from any wire runs to the control/communicator.
- Plug the control/communicator into a different outlet so that it and the radio or television receiver are on different branch circuits.

If necessary, the user should consult the dealer or an experienced radio/television technician for additional suggestions. The user or installer may find the following booklet prepared by the Federal Communications Commission helpful:

### "Interference Handbook"

This booklet is available under Stock No. 004-000-00450-7 from the U.S. Government Printing Office, Washington, DC 20402.

*The user shall not make any changes or modifications to the equipment unless authorized by the Installation Instructions or User's Manual. Unauthorized changes or modifications could void the user's authority to operate the equipment.*

## IN THE EVENT OF TELEPHONE OPERATIONAL PROBLEMS

In the event of telephone operational problems, disconnect the control panel by removing the plug from the RJ31X wall jack. We recommend that the installer demonstrate disconnecting the phones on installation of the system. Do not disconnect the phone connection inside the communicator. Doing so will result in the loss of the phone lines. If the regular phone works correctly after the communicator has been disconnected from the phone lines, the communicator has a problem and should be returned for repair. If, upon disconnection of the communicator, there is still a problem on the line, notify the telephone company that they have a problem and request prompt repair service. The user may not under any circumstances (in or out of warranty) attempt any service or repairs to the system. It must be returned to the factory or an authorized service agency for all repairs.

## FIRE BURGLARY INSTRUMENTS, INC. ONE YEAR LIMITED WARRANTY

Fire Burglary Instruments, Inc. a subsidiary of Pittway Corporation, and Pittway Corporation, its divisions, subsidiaries and affiliates ("Seller"), 149 Eileen Way, Syosset, New York 11791, warrants its security equipment (the "product") to be free from defects in materials and workmanship for one year from date of original purchase, under normal use and service. Seller's obligation is limited to repairing or replacing, at its option, free of charge for parts, labor, or transportation, any product proven to be defective in materials or workmanship under normal use and service. Seller shall have no obligation under this warranty or otherwise if the product is altered or improperly repaired or serviced by anyone other than the Seller. In case of defect, contact the security professional who installed and maintains your security system or the Seller for product repair.

This one year Limited Warranty is in lieu of all other express warranties, obligations or liabilities. THERE ARE NO EXPRESS WARRANTIES WHICH EXTEND BEYOND THE FACE HEREOF. ANY IMPLIED WARRANTIES, OBLIGATIONS OR LIABILITIES MADE BY SELLER IN CONNECTION WITH THIS PRODUCT, INCLUDING ANY IMPLIED WARRANTY OF MERCHANTABILITY, OR FITNESS FOR A PARTICULAR PURPOSE OR OTHERWISE, ARE LIMITED IN DURATION TO A PERIOD OF ONE YEAR FROM THE DATE OF ORIGINAL PURCHASE. ANY ACTION FOR BREACH OF ANY WARRANTY, INCLUDING BUT NOT LIMITED TO ANY IMPLIED WARRANTY OF MERCHANTABILITY, MUST BE BROUGHT WITHIN 18 MONTHS FROM DATE OF ORIGINAL PURCHASE. IN NO CASE SHALL SELLER BE LIABLE TO ANYONE FOR ANY CONSEQUENTIAL OR INCIDENTAL DAMAGES FOR BREACH OF THIS OR ANY OTHER WARRANTY, EXPRESS OR IMPLIED, OR UPON ANY OTHER BASIS OF LIABILITY WHATSOEVER, EVEN IF THE LOSS OR DAMAGE IS CAUSED BY THE SELLER'S OWN NEGLIGENCE OR FAULT. Some states do not allow limitation on how long an implied warranty lasts or the exclusion or limitation of incidental or consequential damages, so the above limitation or exclusion may not apply to you.

Seller does not represent that the product may not be compromised or circumvented; that the product will prevent any personal injury or property loss by burglary, robbery, fire or otherwise; or that the product will in all cases provide adequate warning or protection. Buyer understands that a properly installed and maintained alarm may only reduce the risk of a burglary, robbery, fire or other events occurring without providing an alarm, but it is not insurance or a guarantee that such will not occur or that there will be no personal injury or property loss as a result. CONSEQUENTLY, SELLER SHALL HAVE NO LIABILITY FOR ANY PERSONAL INJURY, PROPERTY DAMAGE OR OTHER LOSS BASED ON A CLAIM THE PRODUCT FAILED TO GIVE WARNING. HOWEVER, IF SELLER IS HELD LIABLE, WHETHER DIRECTLY OR INDIRECTLY, FOR ANY LOSS OR DAMAGE ARISING UNDER THIS LIMITED WARRANTY OR OTHERWISE, REGARDLESS OF CAUSE OR ORIGIN, SELLER'S MAXIMUM LIABILITY SHALL NOT IN ANY CASE EXCEED THE PURCHASE PRICE OF THE PRODUCT, WHICH SHALL BE THE COMPLETE AND EXCLUSIVE REMEDY AGAINST SELLER. This warranty gives you specific legal rights, and you may also have other rights which vary from state to state. No increase or alteration, written or verbal, to this warranty is authorized.



FIRE BURGLARY INSTRUMENTS, INC.

A Subsidiary of Pittway Corp.